

MANUAL



AUTOMATIC TYRE INFLATION SYSTEM

BY



EXCLUSIVELY DISTRIBUTED IN EUROPE BY



Index

Index of Abbreviations.....	IV
Index of Figures.....	IV
Index of Tables.....	IV
1. Important Customer Information	1
2. General Information.....	2
2.1. Safety Icons	2
2.2. Safety Information	3
2.2.1. General	3
2.2.2. Traffic	4
2.2.3. Installation.....	5
2.2.4. Initial Operation	6
2.2.5. Operation	7
2.2.6. Maintenance	7
2.3. General Terms and Conditions and Guarantee	8
2.4. Liability	8
2.5. Disposal	8
3. Product Description and Specifications.....	9
3.1. Appropriate Use	9
3.2. In-Appropriate Use	10
3.3. System Construction	11
3.3.1. Control Box.....	12
3.3.2. Warning Light	12
3.3.3. Stator and Rotary Union.....	12
3.3.4. Tyre Hose.....	13
3.3.5. Press Plug	13

4.	Installation	14
4.1.	Tools – Overview	15
4.2.	Torque – Overview	16
4.3.	Installation Control Box	17
4.4.	Installation Warning Light	19
4.5.	Installation Axle-Inlet (Pressurised Version).....	20
4.6.	Installation Strain Relief (Non-Pressurised Version).....	21
4.7.	Installation Air Line.....	22
4.8.	Installation Press Plug (Hollow Spindle)	23
4.9.	Installation Stator (Pressurised Version)	24
4.10.	Installation Stator (Non-Pressurised Version)	25
4.11.	Installation Hubcap-Adaptor	26
4.12.	Installation Rotary Union.....	27
4.13.	Installation Tyre Hose	28
5.	Initial Operation	29
5.1.	Check Set Pressure	29
5.2.	Adapt Set Pressure	30
5.3.	Function Warning Light	31
5.3.1.	Flashing Warning Light	31
5.3.2.	Lighted Warning Light	32
6.	Tyre Change	32
6.1.	Disassembly.....	33
6.2.	Assembly	33
7.	Overview Spare Parts	33
8.	Maintenance	34
8.1.	Before Departure	34
8.2.	Maintenance Interval	35

8.3.	Maintenance Kits.....	36
8.3.1.	Full Maintenance Kits	37
8.3.2.	Half Maintenance Kits	38
9.	Diagnostics	39
10.	Pressure Change.....	41
11.	Drilling Templates	42
11.1.	Control Box.....	42
11.2.	Warning Light	42

Index of Abbreviations

ADR	Accord européen relatif au transport international des marchandises Dangereuses par Route (European Agreement concerning the International Carriage of Dangerous Goods by Road)
ATIS	Automatic Tyre Inflation System
DRS	Drag Reduction Systems
NPT	National Pipe Thread
OEM	Original Equipment Manufacturer
PA	Polyamide
PSI	Pressure Systems International
PTFE	Polytetrafluoroethylene (Teflon)

Index of Figures

Figure 1: System Construction	11
Figure 2: Control Box	18
Figure 3: Warning Light.....	19
Figure 4: Electrical Connections Warning Light	20
Figure 5: Drilling template Control Box.....	43
Figure 6: Drilling template Warning Light	44

Index of Tables

Table 1: Tools-Overview	15
Table 2: Torque - Overview.....	16
Table 3: Maintenance Interval	35
Table 4: Full Maintenance Kits.....	37
Table 5: Half Maintenance Kits	38
Table 6: Diagnostics	39
Table 7: Pressure Change.....	41

1. Important Customer Information

Dear Customer

We are happy to provide you with an Automatic Tyre Inflation System (ATIS) from Pressure Systems International (PSI). The system will help you to increase the road safety, the environmental friendliness and the profitability of your vehicle.

The current manual will give you an overview about the product and proper usage. Please read this manual in full. Included is also security information and important notes for the correct handling. By observance of these notes its uptime and the lifetime also is optimised.

The manual should be accessible for the vehicle user at all times and therefore you should store it in the vehicle.

With best regards

Your Celerity DRS Team

** Information contained in this publication was in effect at the time the publication was approved for printing and is subject to change without notice or liability. Celerity DRS GmbH, reserves the right to revise the information presented or to discontinue the production of parts described at any time.*

2. General Information

This manual is designed for the user to understand the function, the structure and also how to operate the system. The included guide for the installation and the initial operation is limited to the use by the vehicle manufacturer or via a verified partner and by trained professionals. Celerity DRS advise, that all pressure changes and the maintenance should be done by a verified partner and by trained professionals.

Please read the manual carefully! Failure to follow the warnings and instructions may result in personal or property damages.

2.1. Safety Icons

This manual uses different icons in order to identify important information. It is necessary to read and observed this information carefully.



This icon indicates the vehicle must stop as soon, and safely as possible.



This icon warns for possible safety risks to both persons and property.



This icon identifies special installation requirements. Non-compliance could lead to personal and property damages and also to malfunction or damage of the system.



This icon gives important or useful information for the installation, increased efficiency and increased life-time of the system.

2.2. Safety Information



Warning:

- Please read the manual carefully! Failure to follow the warnings and instructions may result in personal and property damages.
- Save this manual for future reference!

2.2.1. General



Warning:

- Physical alteration of the system is not permitted without notifying Celerity DRS GmbH. All required changes on the system must be confirmed in writing to Celerity DRS GmbH.
- Painting of the ATIS parts is not permitted.
- Transportation and storage should be done in the original packaging and kept cool and dry.
- The axle of a semi-trailer or a trailer is a safety-relevant part. For that reason, the installation should be done only via the vehicle manufacturer or via a verified partner and by trained professionals.
- The system works with compressed air. For that reason, safety glasses must be worn during the installation and also during maintenance at a later time.
- Damaged or missing parts must be replaced immediately by a verified partner and by trained professionals.
- Before working on the system, the safety valve must be closed and the air released from the pressure relief valve at the control box.
- Axle kits are supplied for specific axle OEM and axle specification. Kits must not be used for none corresponding axle types.
- An inlet pressure of minimum 6 bar is required for a working system.
- The working area is between the inlet pressure (minimum 6 bar) and 11 bar.

- Excess air will be released from the control box, as the pump pulsates, via the rubber exhaust at the bottom of the control box, see chapter 4.2 Figure 2.
- Park the vehicle on a level surface. Block the wheels to prevent the vehicle from moving. Support the vehicle with safety stands. Do not work under a vehicle supported only by jacks. Jacks can slip and cause serious injury or fatality.
- Verify that the vent holes in the hubcap-adaptor are not blocked. Blocked vent holes will prevent system air from venting from the wheel end. Serious personal injury and damage to components can result.
- Test the tire inflation system for air leaks before you place the vehicle into service. Spray a non-corrosive leak detection solution on all fittings and connections (this can be soapy water). Listen for audible leaks and check for bubbles. If you detect a leak, identify the source and replace parts as required. Air leaks in the tire inflation system can cause damage to components during operation.

2.2.2. Traffic



Warning:

- The driver's duties regarding their walk round check of the vehicle before departure remain the same.
- Check if the security valve is open and so the function of the ATIS is given.
- Check the tyre conditions for outer damages and sufficient tread depth.
- An incorrect set pressure can lead to an increase in tyre wear and fuel consumption and in the worst case to the blow-out of a tyre.

2.2.3. Installation



Warning:

- An incorrect instillation can cause serious accidents and even lead to the loss of the operating license. As a consequence, there could be personal and property damages.
- All installation location must be checked before drilling that there is no power supply, air lines or load bearing parts in the way.
- A pressure of 9.2 bar is pre-set at the control box unless specified.
- There must be at least a 5 cm gap between the rubber air outlet and the chassis of the trailer.
- The rubber air outlet must be not pushed in.
- To secure the seal tightness at the cable gland, a round cable with a diameter of 6-10 mm must be used.
- The ADR-Guidelines must be observed for the cabling of ADR-vehicles.
- The connection cable to the control box must be installed so that it is protected from the threat of any damages.
- All threads must be free of dirt, greases or oils.
- The air line must be installed, so that it will not be subject to damage, kinking or rubbing against other lines.
- At the installation of the air line there must be enough slack for the spring extension and compression.
- Before working on the air line, the air circulation system must be deflated and the security valve closed.
- The filter of the stator must not be broken off or hanging loose from stator tube, if the filter is broken off or hanging loose from the stator tube, it must be replaced.
- The hubcap adaptor must be aligned with the stator.
- An incorrectly installed hubcap-adaptor can damage the stator and the rotary union. This could lead to extensive wear on the O-rings with malfunctioning at an early stage (leaking).
- The Rotary union has to be installed after the hubcap. The installation of the hubcap together with the rotary union can lead to damages of the rotary union and the O-ring of the stator, which may cause leakages.
- The needle of the rotary union must be aligned with the stator.

- **The Tyre hose must not be kinked, cover the wheel nuts or sit outside the confines of the wheel arch.**
- **A damaged tyre hose can lead to a complete deflation of the tyre.**
- **Do not overtighten the tyre hose connections, this may damage the hose seal and cause a tire to deflate when the trailer is parked. Damage to components can result. (See chapter 4.13. at page 28.)**
- **Only use the approved retaining compound when you install the axle press plug. Only apply retaining compound to the OUTSIDE diameter of the axle press plug. Do not apply it to the inside diameter of the spindle bore, axle press plugs stator threads or axle spindle threads. Damage to components can result. (See chapter 4.8. at page 23.)**

2.2.4. Initial Operation



Warning:

- **Before the system is put into operation all of the parts must be checked for any damages or leakage. Also, the pressure of the control box and all of the tyres must be checked.**
- **The pressure setting at the pressure control valve must be 0,2 bar above the tyre manufacturer's recommended tyre pressure, to compensate the opening pressure of the pressure valve.**

2.2.5. Operation



Warning:

- When the warning light has been active flashing over a longer time period (10 minutes) in a high frequency the system may not be in operation, all tyres and the system must be checked by an authorised workshop.



Stop:

- When the warning light is constantly illuminated, the driver must stop as soon as possible. The system is not able to compensate the air leakage anymore. There is then danger of a blow-out.

2.2.6. Maintenance



Warning:

- The number of maintenance intervals must be increased when there are extreme operating conditions related to weather and terrain.
- A non-compliance of the maintenance intervals will lead to the loss of the guarantee.
- Maintenance kits are supplied for specific axle OEM and axle specification. Kits must not be used for non-corresponding axle types.

2.3. General Terms and Conditions and Guarantee

The current general terms and conditions and also the guarantee conditions of Celerity DRS GmbH can be downloaded from our website www.celeritydrs.com.

2.4. Liability

The ATIS of PSI is subject to the current general terms and conditions of Celerity DRS GmbH.

Celerity DRS GmbH takes over no liability by personal or property damages, which are due to the following causes:

- Use of the system which is not appropriate.
- The manual and the safety information not being observed.
- Physical alteration of the system.
- Poor maintenance of the wear parts.
- Use of damaged parts.
- In-appropriate installation of the system.
- Use of non-authorized aftermarket parts.
- Any disaster due to outside influence or an act of nature.

2.5. Disposal

To protect our environment, during the installation or maintenance intervals waste material, e. g. parts, and operating supplies must be disposed of correctly.

All recyclable waste material, free of special waste like oil and grease, must be reused where possible. All special requirements such as EU-regulations and regional regulations must be observed.

3. Product Description and Specifications

3.1. Appropriate Use

The manufacturing of the product is done with the latest state of the art equipment, whereby the primary focus is on safety. Despite this there could occur dangers for persons and property by using the product.

The ATIS by PSI is only designed and approved for the tyre pressure control on heavy duty semi-trailers and trailers. The system ensures, that the tyre pressure of the semi-trailers and trailers is constantly at or above the minimum cold pressure setting, which is pre-set depending on the load and the tyre specification. The driver will be notified of the air supply, via a warning light fitted to the semi-trailer or trailer in the viewing area (rear-view mirror) of the driver.

The warning light will flash with differing speeds depending on the severity of the air leak. In the event that the warning light is flashing almost continuously, the vehicle must stop as soon as possible and the tyres and the system must be checked. Depending on the axle OEM and the axle-type there are different product configurations. The single product configurations are allowed only for use with the associated axle.

Also related to appropriate use:

- The manual and the included working steps must be observed.
- The guidelines for the installation must be followed.
- The guidelines for the checks must be followed.
- The guidelines for the environmentally sound disposal must be followed.

Only when all of the valid system settings, are observed, can a reliable use be ensured.

3.2. In-Appropriate Use

The ATIS by PSI is only designed and approved for the tyre pressure control on heavy duty semi-trailers and trailer designed only.

Related to the in-appropriate use counts also:

- Filling or pressurising of facilities, tanks or parts, which are not belonging to the ATIS of PSI.
- Usage of the ATIS as a tyre pressure regulation system.
- Usage of kits for non-corresponding axle types.
- Installation by non-authorized workshops or professionals.
- All non-recommended applications.

3.3. System Construction

Figure 1: System Construction

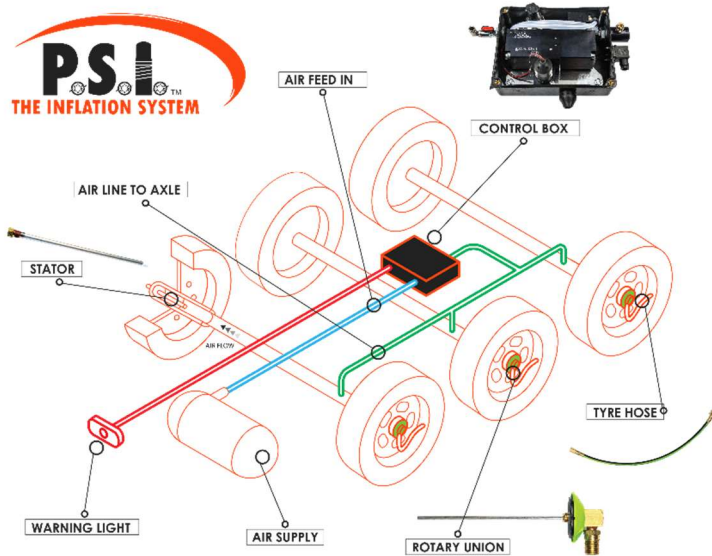

Components:

- 1) Control Box
- 2) Warning Light
- 3) Stator
- 4) Rotary Union
- 5) Tyre Hose
- 6) Air Supply*
- 7) Air Line*

*Described components are not included in the delivery contents.

3.3.1. Control Box

The control box includes a step-up pump, a generator, a pressure protection valve, a pressure relief valve, a pressure control valve and a security valve. The step-up pump increases the incoming air pressure by a factor of 1.7, until the requested outlet pressure is achieved. The generator illuminates the warning light when the system delivers an excessive amount of air to either a leaking tire or a leaking tire inflation system component. Depending on the amount of air, the light will flash at a different speed. The pressure protection valve ensures that air is available for other trailer functions and maintains air tank pressure if a tire or a tire inflation system component is damaged. The pressure relief valve is used to manually exhaust pressure from the tire inflation system, which enables you to perform maintenance on either the trailer axle components or the tire inflation system. Furthermore, the pressure relief valve will open automatically at a pressure of over 11 bar. The pressure control valve is used to adjust system air pressure as the system air pressure should be adjusted to the customer's recommended tire pressure. The security valve allows air delivery to the system and also stops air delivery to the system.

3.3.2. Warning Light

A warning light mounted to the trailer comes ON when the system delivers an excessive amount of air due to a leaking tire or tire inflation system component.

3.3.3. Stator and Rotary Union

The stator is located inside the axle spindle and the rotary union is attached to the hubcap. Pressurised air passes from the stationary axle interior to the rotating hub through a needle extending from the rotary union into the stator. Dynamic seals, located in the rotary union and stator, allow rotation without loss of air pressure. The deflector shield at the rotary union helps prevent any contaminants such as dirt and water from entering the wheel end. The particulate filter at the stator removes contaminants from the air system.

3.3.4. Tyre Hose

The hose is a flexible valve stem extension which mechanically opens the tyre valve core and allows air to pass into a tyre. A check valve located at the knurled end of the hose allows air to flow in only one direction-towards the tire, which protects each tire from loss of air pressure if the tyre inflation system, or any tyre, loses air pressure during operation.

3.3.5. Press Plug

The axle press plug is used in axles with hollow spindles to seal off the pressurised axle interior from the wheel end and provide a means of holding and securing the stator.

4. Installation

The following Chapter is concerned with the installation of the automatic tyre inflation system. The described working steps must be followed and the notes must be observed.



Warning:

- Please read all safety information which can be found in chapter 2.2.
- A non-compliance can lead to personal and property damages!



Note:

- The PSI system can be routed to the wheel end in two different ways. The most common is where the axle is pressurised and acts as an air conduit. Alternatively, where the axle cannot be pressurised (an axle design which is not air tight), it must be internally tubed. Please consider your axle type and the different installation steps.
- There are two different axle types available on the market. The most common axle type in Europe is the solid spindle axle, most solid spindle trailer axles have a forged spindle welded to the axle tube. The second axle type is the hollow spindle axle. Most hollow spindle trailer axles have a spindle that's integrally formed out of axle tube material. A welsh plug is pressed into a machined recess in the end of the spindle. If you're unsure of the axle type, contact the axle manufacturer.
- Nearly all axle OEMs offer a factory prepared axle for the ATIS by PSI. The preparing of the axles varies and therefore the kits are not interchangeable.

4.1. Tools – Overview



Note:

- If special tools and supplies are specified in this manual, please contact Celerity DRS for more information.

Table 1: Tools-Overview

Axle Version?	Which Parts?	Which Tool?	Possible Sizes? *
Pressurised; Non-Pressurised	Stator	Torque Wrench	16 mm
Pressurised; Non-Pressurised	Hubcap-Adaptor	Torque Wrench	22 mm
Pressurised; Non-Pressurised	Spindle Plug	Torque Wrench	32 mm
Pressurised; Non-Pressurised	Tyre Hoses	Wrench	11 mm
Pressurised; Non-Pressurised	Control Box; Warning Light	Cross Tip Screwdriver	Standard/Small
Pressurised; Non-Pressurised	PG11-Adaptor	Slotted Screwdriver	Small
Pressurised	Blind Plug	Torque Wrench	22 mm
Pressurised	Axle-Inlet	Wrench	11/13/14/17/22 mm
Non-Pressurised	Strain Relief	Wrench	12/24 mm
Non-Pressurised	Installation of the inner air line.	Flexible Wire	
Pressurised; Non-Pressurised	Press Plug	Slide Hammer	Welsh Plug Removal Spear; Press Plug Remover
Pressurised; Non-Pressurised	Press Plug	Driver Handle, Driver Head	35/46/58/64/70 mm

*The sizes depend on the Axle type.

4.2. Torque – Overview

Table 2: Torque - Overview

Axle Manufacturer?	Which Part?	Requested Torque? *
BPW, SAF, Gigant, JOST, VALX, ROR, SMB/SAE, YORK	Stator	40 Nm \pm 5 Nm
Schmitz Cargobull	Stator	70 Nm \pm 5 Nm
JOST	Reducer	40 Nm \pm 5 Nm
Gigant, JOST, Schmitz Cargobull, SMB/SAE, YORK	Hubcap-Adaptor	30 Nm \pm 2 Nm
ROR (self-drilled)	Hubcap-Adaptor	Tbd.
SAF (self-drilled)	Hubcap-Adaptor	Tbd.
VALX	Hubcap-Adaptor	25 Nm \pm 5 Nm
BPW	Hubcap ECO Plus	800 Nm
BPW	Hubcap ECO Plus 3	350 Nm
All	Fittings, Blind Plug	25 Nm \pm 5 Nm
All	Rotary Union	Hand tight (6 Nm)
All	Axle Inlet	Hand tight (5 Nm)
All	Tyre Hose / Tyre Valve	Hand tight + $\frac{1}{2}$ turn with a wrench.
All	Tyre Hose / Rotary Union	Hand tight (5 Nm)
All	Strain Relief	Hand tight (5 Nm)

4.3. Installation Control Box



Warning:

- Please read all safety information which can be found in chapter 2.2.
- A non-compliance can lead to personal and property damages!
- It is essential that the rubber exhaust at the bottom of the control box is not pressed up against the chassis and has at least 50mm space free underneath, this is so that it can safely emit residual air that is used to pump up the pressure.



Note:

- The lid of the CMP must be accessible for any maintenance, that means it must be removable.
- Excess air will be released from the control box.

Control Box contains:

- Pressure Control Valve
- Pressure Protection Valve
- Generator
- Step-up Pump
- Pressure Security Valve
- PG11-Connector for the Warning Light

Figure 2: Control Box

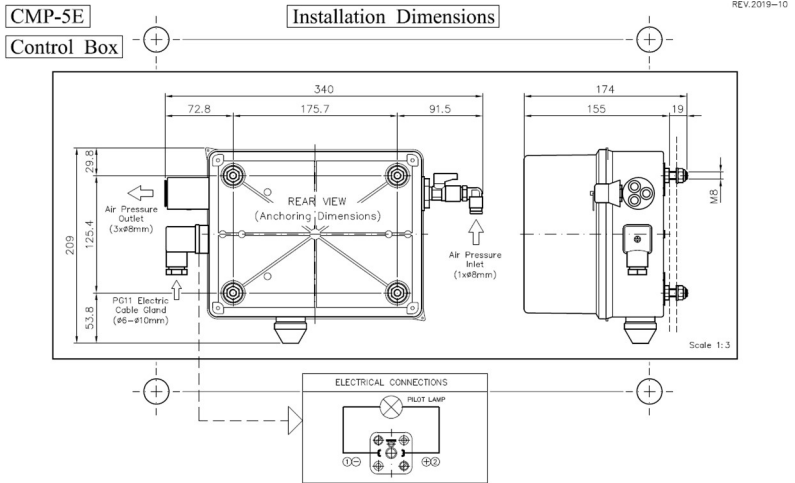

Procedure:

- 1) For the mounting of the control box the holes must be drilled in accordance with the previous drawing at the installation stage.
- 2) The installation location must be protected but still accessible.
- 3) Mounting of the control box must be carried out with the included screws.

4.4. Installation Warning Light



Warning:

- Please read all safety information which can be found in chapter 2.2.
- A non-compliance can lead to personal and property damages!



Note:

- The warning light should be installed in the viewing area (rear-view mirror) of the driver.
- The connection cables required to connect the warning light with the control box are not part of the delivery contents.
- The cable ties required to install the connection cable are not part of the delivery contents.
- The warning light is available in the colors red and violet.
- Cable colour: Black (+) / White (-).

Figure 3: Warning Light

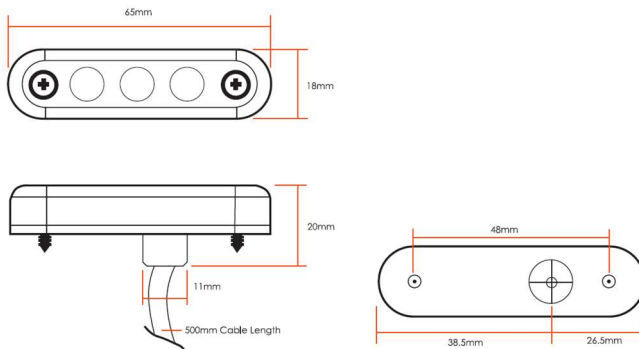

Procedure:

- 1) For the mounting of the warning light the holes must be drilled in accordance with the previous drawing at the installation stage.

- 2) Installation of the warning light should be in the viewing area (rear-view mirror) of the driver.
- 3) The connection cable to the control box should be installed in accordance of the previous drawing.
- 4) Create a leakage to test the warning light by releasing the pressure relief valve on top of the air pressure outlet.

Figure 4: Electrical Connections Warning Light

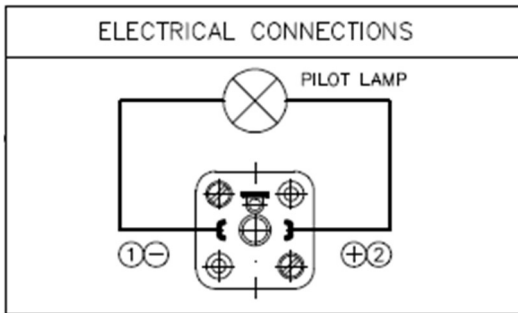

4.5. Installation Axle-Inlet (Pressurised Version)



Warning:

- Please read all safety information which can be found in chapter 2.2.
- A non-compliance can lead to personal and property damages!



Attention:

- Tighten it with a torque wrench and a torque of 5 Nm.

Procedure:

- 1) Cover the thread of the axle-inlet with sealant (e. g. PTFE-sealing tape) if necessary.
- 2) Screw in the axle-inlet, align and tighten it up.

4.6. Installation Strain Relief (Non-Pressurised Version)



Warning:

- Please read all safety information which can be found in chapter 2.2.
- A non-compliance can lead to personal and property damages!



Attention:

- Hand tighten it with a wrench.
- Please do not install the t-piece at the axle, this could lead to air leaks through vibration.



Note:

- The air lines (6x1 mm PA12-hose) required to conduct air to stators are not part of the delivery contents.

Procedure:

- 1) Pull inner air line through the strain relief.
- 2) Screw in the strain relief (kink protection is outside the axle) and hand tighten it with a wrench.
- 3) Connect both inner air lines with a t-piece.
- 4) Install the t-piece at the chassis of the trailer.

4.7. Installation Air Line



Warning:

- Please read all safety information which can be found in chapter 2.2.
- A non-compliance can lead to personal and property damages!



Attention:

- Use a reducer (8mm-6mm) for the installation of the air line at the control box (non-pressurised version).



Note:

- The air lines (8x1 mm PA12-hose) required to conduct air to axles are not part of the delivery contents (pressurised version).
- The air lines (6x1 mm PA12-hose) required to conduct air to axles are not part of the delivery contents (non-pressurised version).
- The cable ties required to install the air line are not part of the delivery contents.

Procedure:

- 1) Measure out the air line and install under the vehicle.
(Air Supply -> Control Box; Control Box -> Axle)
- 2) Install air line at the control box.

4.8. Installation Press Plug (Hollow Spindle)



Warning:

- Please read all safety information which can be found in chapter 2.2.
- A non-compliance can lead to personal and property damages!



Attention:

- Use latex gloves to protect your skin.
- Loctite® 620, 3M RT20 and PermaBond HH 0040 are all approved retaining compounds.
- The tyre inflation system can be pressurized 30 minutes after installation of the axle press plug.

Procedure:

- 1) Remove the spindle welsh plug with a slide hammer fitted with the welsh plug removal, be careful not to score the inside diameter of the spindle bore.
- 2) Polish the spindle bore to remove all adhesive residue left from the old press plug and any metal burrs or sharp edges from the spindle bore surface.
- 3) Clean the surface and remove all debris, including loose rust, scale, liquid and machining residue.
- 4) Clean the exposed O-ring surface and outside diameter surface of one axle press plug. Protect the clean plug from additional contaminants.
- 5) Apply only the approved retaining compound evenly to the OUTSIDE diameter of the axle press plug. The axle press plug must be installed within 10 minutes of applying the retaining compound to ensure that the compound hardens correctly.
- 6) Insert the axle press plug into the spindle bore by hand until the plug stops in the bore.
- 7) Insert the axle press plug drive adaptor + drive handle into the axle press plug.

- 8) Use a four-pound brass or synthetic mallet to drive the axle press plug into the spindle bore, until the drive adaptor bottoms out squarely on the end of the spindle. The drive adaptor sets the axle press plug installation depth. There will be a definite change in the sound and feel of the hammering when the drive adaptor bottoms out.
- 9) Wipe off all retaining compound residue from the spindle and axle press plug drive adaptor.

4.9. Installation Stator (Pressurised Version)



Warning:

- Please read all safety information which can be found in chapter 2.2.
- A non-compliance can lead to personal and property damages!



Attention:

- Tighten it with a torque wrench and the axle specific torque. (See chapter 4.2. at page 16.)
- If there is a special Spindle Plug (Reducer M22 -> ¼ NPT) required, tighten the Spindle Plug with a torque of 40 Nm and the Stator with a torque of 40 Nm.

Procedure:

- 1) Check the filter for damages and dirt before installation.
- 2) Check if a spindle plug is needed. If yes, screw in the spindle plug and tighten it up.
- 3) Cover the thread of the stator with sealant (e. g. PTFE-sealing tape) if necessary.
- 4) Screw in the stator and tighten it up.

4.10. Installation Stator (Non-Pressurised Version)



Warning:

- Please read all safety information which can be found in chapter 2.2.
- A non-compliance can lead to personal and property damages!



Attention:

- Tighten it with a torque wrench and the axle specific torque. (See chapter 4.2. at page 16.)
- If there is a special Spindle Plug (Reducer M22 -> ¼ NPT) required, tighten the Spindle Plug with a torque of 40 Nm and the Stator with a torque of 40 Nm.

Procedure:

- 1) Check if a spindle plug is needed. If yes, screw in the spindle plug and tighten it up.
- 2) Pull an air line through the spindle and the axle-outlet.
- 3) Cover the thread of the stator with sealant (e. g. PTFE-sealing tape) if necessary.
- 4) Connect the inner air line with the stator.
- 5) Screw in the stator and tighten it up.

4.11. Installation Hubcap-Adaptor



Warning:

- Please read all safety information which can be found in chapter 2.2.
- A non-compliance can lead to personal and property damages!



Attention:

- Tighten it with a torque wrench. See chapter 4.2. to get the requested torque for your system.
- Install the hubcaps regarding the specific requirements of the axle manufacturer.
- The sealing of the BPW-hubcap must be replaced during the installation.
- Use for BPW axles only the original BPW hubcap adaptor.



Note:

- Some axle OEMs deliver a special hubcap with a pre-installed hubcap-adaptor or a pre-drilled hubcap.
- The usage of a hubcap with a pre-installed hubcap adaptor or pre-drilled hubcap is highly recommended!
- For some hubcaps, retention brackets are necessary to secure a durable fitting.

Procedure:

- 1) If no prepared hubcap is available, drill a hole with \varnothing 14 mm in the centre of the hubcap.
- 2) Install the hubcap-adaptor and check the correct fitting.
- 3) If no prepared hubcap is available, drill 3 holes with \varnothing 1.5 mm in the hubcap using the hubcap adaptor as a template. For the exhaust air in case of a stator leak.
- 4) Install the hubcap on the axle spindle and check the correct fitting.
- 5) Install the retention brackets if necessary.

4.12. Installation Rotary Union



Warning:

- Please read all safety information which can be found in chapter 2.2.
- A non-compliance can lead to personal and property damages!



Attention:

- Tighten it with a recommended torque of max. 6 Nm.
- BPW axles require a white PTFE O-ring at the rotary union.

Procedure:

- 1) Screw in the rotary union to the hubcap-adaptor.
- 2) Hand tighten and use a wrench to obtain a good orientation of the rotary union, hose and tyre valve.
- 3) Check the fitting is correct.

4.13. Installation Tyre Hose



Warning:

- Please read all safety information which can be found in chapter 2.2.
- A non-compliance can lead to personal and property damages!



Attention:

- The Tyre hose must be hand tightened (no tools needed) at the rotary union.
- The Tyre hose must be firstly hand tightened and afterwards tightened with $\frac{1}{2}$ a turn of a wrench at the tyre valve.
- There must be between 12-15 mm at the top of the tyre valve, so that there is the same depth as the thread to ensure a tight fitting.



Note:

- Function test of the tyre hose -> Install the tyre hose at the tyre valve and push down the integrated valve in the tyre hose, at this point air should stream out.

Procedure:

- 1) Install tyre hose at the tyre valve.
- 2) Function test of the tyre hose.
- 3) Install tyre hose at the rotary union.
- 4) Check tyre valve for leakages!

5. Initial Operation



Warning:

- **Please read all safety information which can be found in chapter 2.2.**
- **A non-compliance can lead to personal and property damages!**

5.1. Check Set Pressure



Warning:

- **Please read all safety information which can be found in chapter 2.2.**
- **A non-compliance can lead to personal and property damages!**



Note:

- **The usage of a digital calibrated gauge is highly recommended.**

Procedure:

- 1) Close the safety valve (stopcock) and open the safety pressure valve.
- 2) Remove the air lines from the control box to the axles.
- 3) Install the gauge into one of the three-way air outlets of the control box.
- 4) Bridge or close the two other outlets.
- 5) Open the safety valve (stopcock).
- 6) After the pump pulsates, the pressure can be read from the gauge.
- 7) Release the air over the safety pressure valve and repeat the checking process a further two times.
- 8) Re-Install the air lines to the axles.

5.2. Adapt Set Pressure



Warning:

- Please read all safety information which can be found in chapter 2.2.
- A non-compliance can lead to personal and property damages!



Note:

- The usage of a digital calibrated gauge is strongly recommended.

Procedure:

- 1) Close the safety valve and open the safety pressure valve.
- 2) Remove the air lines to the axles from the control box.
- 3) Install the gauge into one of the three-way air outlet of the control box.
- 4) Bridge or close the two other outlets.
- 5) Open the safety valve (stopcock).
- 6) After the pump pulsates, the pressure can be read from the gauge.
- 7) For reduction of the pressure, pull out the adjustment knob of the pressure safety valve and turn in small steps to the left.
- 8) For increase of the pressure, pull out the adjustment knob of the pressure safety valve and turn in small steps to the right.
- 9) Release the air over the safety pressure valve and repeat the checking process a further two times.
- 10) Lock the safety pressure valve by pushing in the adjustment knob.
- 11) Re-install the lid carefully and hand tighten the four screws.
- 12) Check the pressure again with the pressure gauge after closing the lid. If the pressure is correct proceed with the next step, otherwise repeat the sequence.
- 13) Re-Install the air lines to the axles.
- 14) Note the changed pressure. (See chapter 10. at page 41.)

5.3. Function Warning Light



Warning:

- Please read all safety information which can be found in chapter 2.2.
- A non-compliance can lead to personal and property damages!



Note:

- A flashing warning light signifies that the system is in use, and can compensate the air loss.
- Check that the light is in working order before usage, test with the release of air from one of the hoses, if the light flashes when the pump pulsates to compensate for the air - it is operational.

5.3.1. Flashing Warning Light



Warning:

- Please read all safety information which can be found in chapter 2.2.
- A non-compliance can lead to personal and property damages!

Procedure:

- 1.) In the event of a flashing warning light, the driver can continue with their journey.
- 2.) Tyres and the system must be checked when stopped.

5.3.2. Lighted Warning Light



Warning:

- Please read all safety information which can be found in chapter 2.2.
- A non-compliance can lead to personal and property damages!

Procedure:

- 1) When the warning light is constantly illuminated, the vehicle must stop as soon as possible.
- 2) Damages from the air loss must be repaired before continuation of the journey by an authorised workshop.

6. Tyre Change



Warning:

- Please read all safety information which can be found in chapter 2.2.
- A non-compliance can lead to personal and property damages!



Attention:

- The Tyre hose must be hand tightened (no tools needed) at the rotary union.
- The Tyre hose must be firstly hand tightened and afterwards tightened with $\frac{1}{2}$ a turn of a wrench at the tyre valve.



Note:

- Function test of the tyre hose -> Install the tyre hose at the tyre valve and push down the integrated valve in the tyre hose, at this point air should stream out.

6.1. Disassembly

Procedure:

- 1) Loosen the tyre hose from the rotary union.
- 2) Loosen the tyre hose from the tyre valve.
- 3) Change the tyre in accordance to the manufacturer guidelines.

6.2. Assembly

Procedure:

- 1) Connect tyre hose at the tyre valve.
- 2) Function test of the tyre hose.
- 3) Connect tyre hose at the rotary union.
- 4) Check tyre valve for leakages!

7. Overview Spare Parts

An overview with all necessary spare parts for your system can be requested by all verified partners or directly from Celerity DRS.

Celerity DRS advise to use only original spare parts of PSI. The impact of non-authorized spare parts on the uptime and possible risk and dangers cannot be judged by Celerity DRS. Therefore, the use of non-authorized spare parts will result in the loss of guarantee.

8. Maintenance



Warning:

- **Please read all safety information which can be found in chapter 2.2.**
- **A non-compliance can lead to personal and property damages!**

8.1. Before Departure



Warning:

- **Please read all safety information which can be found in chapter 2.2.**
- **A non-compliance can lead to personal and property damages!**

Procedure:

- 1) Incorporated in driver's walk round they must check for damages to wheel end components.
- 2) Check the safety valve (stopcock) of the control box. The safety valve (stopcock) must be open.

8.2. Maintenance Interval



Warning:

- Please read all safety information which can be found in chapter 2.2.
- A non-compliance can lead to personal and property damages!

To guarantee the function and durability of the system, it must be regularly checked.

In order to adhere to guarantee, the following check intervals must be observed:

Table 3: Maintenance Interval

Optical Check	
Rotary Unions	Before Departure
Tyre Hoses	Before Departure
Safety Valve (open)	Before Departure
Electric Cable	Yearly
Air Line	Yearly
Function Test	
Check set pressure of the control box. -> First time after installation (See chapter 5.1. at page 29).	Within 6 Month after installation and afterwards yearly.
Check warning light. -> First time after installation (See chapter 4.4. at page 19).	Yearly
Check the total hubcap for leakages (soapy water test). -> First time after installation.	Yearly

8.3. Maintenance Kits



Warning:

- **Please read all safety information which can be found in chapter 2.2.**
- **A non-compliance can lead to personal and property damages!**



Note:

- **Please indicate in each order the number of axles. The following kits are for 3-axle semi-trailers.**

Celerity DRS offers two maintenance kits for different requirements. The full maintenance kit consists of the rotary unions, the stators and the tyre hoses. In addition, Celerity DRS offer half maintenance kits which excluded the tyre hoses.

8.3.1. Full Maintenance Kits

Table 4: Full Maintenance Kits

Description	Part Number	Suitable for
Full Maintenance Kit	MUV-120-150-S-H-3-P	JOS-RFS-120-S-F-3-P; JOS-RFS-120-S-R-3-P; SAF-BB1-120-S-R-3-P
Full Maintenance Kit	MUV-000-090-S-H-3-P	BPW-EP3-000-S-F-3-P; VAL-XXX-000-S-R-3-P; ROR-LMX-000-S-R-3-P
Full Maintenance Kit	MUV-120-090-S-H-3-P	BPW-EP3-120-S-F-3-P; SCB-ROT-120-S-R-3-P; ROR-LMX-120-S-R-3-P; VAL-XXX-120-S-R-3-P
Full Maintenance Kit	ME3-XXX-090-T-H-3-P	BPW-EP3-XXX-T-F-3-P
Full Maintenance Kit	ME3-120-090-S-H-3-N	BPW-EP3-120-S-F-3-N
Full Maintenance Kit	ME3-000-090-S-H-3-N	BPW-EP3-000-S-F-3-N
Full Maintenance Kit	ME3-XXX-090-T-H-3-N	BPW-EP3-XXX-T-F-3-N
Full Maintenance Kit	ME2-000-090-S-H-3-N	BPW-EP2-000-S-R-3-N
Full Maintenance Kit	ME2-120-090-S-H-3-N	BPW-EP2-120-S-R-3-N
Full Maintenance Kit	ME2-XXX-090-T-H-3-N	BPW-EP2-XXX-T-R-3-N
Full Maintenance Kit	MS1-000-150-S-H-3-P	SAF-SS1-000-S-R-3-P
Full Maintenance Kit	MZ1-XXX-150-T-H-3-P	SAF-ZZ1-XXX-T-R-3-P

8.3.2. Half Maintenance Kits

Table 5: Half Maintenance Kits

Description	Part Number	Suitable for
Half Maintenance Kit (without Hoses)	MUV-XXX-150-S-X-3-P	JOS-RFS-120-S-F-3-P; JOS-RFS-120-S-R-3-P; SAF-SS1-000-S-R-3-P; SAF-BB1-120-S-R-3-P
Half Maintenance Kit (without Hoses)	MUV-XXX-090-S-X-3-P	BPW-EP3-000-S-F-3-P; VAL-XXX-000-S-R-3-P; ROR-LMX-000-S-R-3-P; BPW-EP3-120-S-F-3-P; SCB-ROT-120-S-R-3-P; ROR-LMX-120-S-R-3-P; VAL-XXX-120-S-R-3-P
Half Maintenance Kit (without Hoses)	ME3-XXX-090-T-X-3-P	BPW-EP3-XXX-T-F-3-P
Half Maintenance Kit (without Hoses)	MZ1-XXX-150-T-X-3-P	SAF-ZZ1-XXX-T-R-3-P
Half Maintenance Kit (without Hoses)	ME3-XXX-090-S-X-3-N	BPW-EP3-120-S-F-3-N; BPW-EP3-000-S-F-3-N
Half Maintenance Kit (without Hoses)	ME3-XXX-090-T-X-3-N	BPW-EP3-XXX-T-F-3-N
Half Maintenance Kit (without Hoses)	ME2-XXX-090-S-X-3-N	BPW-EP2-000-S-R-3-N; BPW-EP2-120-S-R-3-N
Half Maintenance Kit (without Hoses)	ME2-XXX-090-T-X-3-N	BPW-EP2-XXX-T-R-3-N

9. Diagnostics



Warning:

- Please read all safety information which can be found in chapter 2.2.
- A non-compliance can lead to personal and property damages!

Table 6: Diagnostics

Condition	Possible Causes	Actions
The warning light is ON.	<ul style="list-style-type: none"> a. The system is delivering air during initial system charging. b. The system is delivering air to a leaking tire. c. The system is delivering air to a leaking system component. d. The system is delivering air to a cracked axle. e. The system wiring is incorrect. 	<ul style="list-style-type: none"> a. The system is functioning correctly. b. Repair the tyre. c. Replace the system component. d. Replace the axle. e. Correct the system wiring.
The warning light is ON and air is leaking from the wheel-end rotary union.	<ul style="list-style-type: none"> a. The system is delivering air to a leaking system component. b. The rotary union is leaking. c. The stator O-ring is leaking. d. The stator threads are leaking e. The axle press plug is leaking. 	<ul style="list-style-type: none"> a. Replace the system component. b. Replace the rotary union. c. Replace the stator. d. Seal the stator threads. e. Replace the axle press plug.
The warning light is OFF during system operation, with air flowing through the control box.	<ul style="list-style-type: none"> a. The warning light is inoperative. b. The generator is inoperative. c. The system wiring is damaged. d. The system wiring is incorrect. 	<ul style="list-style-type: none"> a. Replace the warning light. b. Replace the generator. c. Repair the system wiring. d. Correct the system wiring.
Air is leaking from the wheel-end rotary union.	<ul style="list-style-type: none"> a. The rotary union is leaking. b. The stator is leaking. c. The stator threads are leaking. d. The axle press plug is leaking. 	<ul style="list-style-type: none"> a. Replace the rotary union. b. Replace the stator. c. Seal the stator threads. d. Replace the axle press plug.
Tyre pressure is low.	<ul style="list-style-type: none"> a. The security valve is closed. b. The system pressure setting is too low. 	<ul style="list-style-type: none"> a. Open the security valve at the control box. b. Increase the system pressure setting.

Condition	Possible Causes	Actions
Tyre pressure is high.	<ul style="list-style-type: none"> a. The tyre is manually over inflated b. The system pressure setting is too high. 	<ul style="list-style-type: none"> a. Reduce the tyre pressure. The system will inflate to the correct level. b. Lower the system pressure setting.
The trailer deflates when parked.	<ul style="list-style-type: none"> a. The system hose or tyre valve stem connection is leaking. b. The hose valve core is leaking. c. The tyre is leaking. 	<ul style="list-style-type: none"> a. Correctly tighten the connection, replace the seals or replace the valve stamp. b. Clean or replace the hose valve core. c. Repair the tyre.
The tyre is slow to inflate or no air flows to the tire.	<ul style="list-style-type: none"> a. The hose connection to the valve stem may have been overtightened, blocking air flow. 	<ul style="list-style-type: none"> a. Correctly tighten the connection or replace the hose or seal if it is damaged.

10. Pressure Change

Table 7: Pressure Change

Set Pressure	Reason	Date and Sign

11. Drilling Templates

For an easier installation of the control box and the warning light you can use our drilling templates.

11.1. Control Box

Procedure:

- 1) Please remove the drilling template from the manual.
(See page 43.)
- 2) Clean the installation area and stick the template on it.
- 3) Do the installations as described in chapter 4.3.
(See page 17.)

11.2. Warning Light

Procedure:

- 1) Please remove the drilling template from the manual.
(See page 44.)
- 2) Clean the installation area and stick the template on it.
- 3) Do the installations as described in chapter 4.4.
(See page 19.)

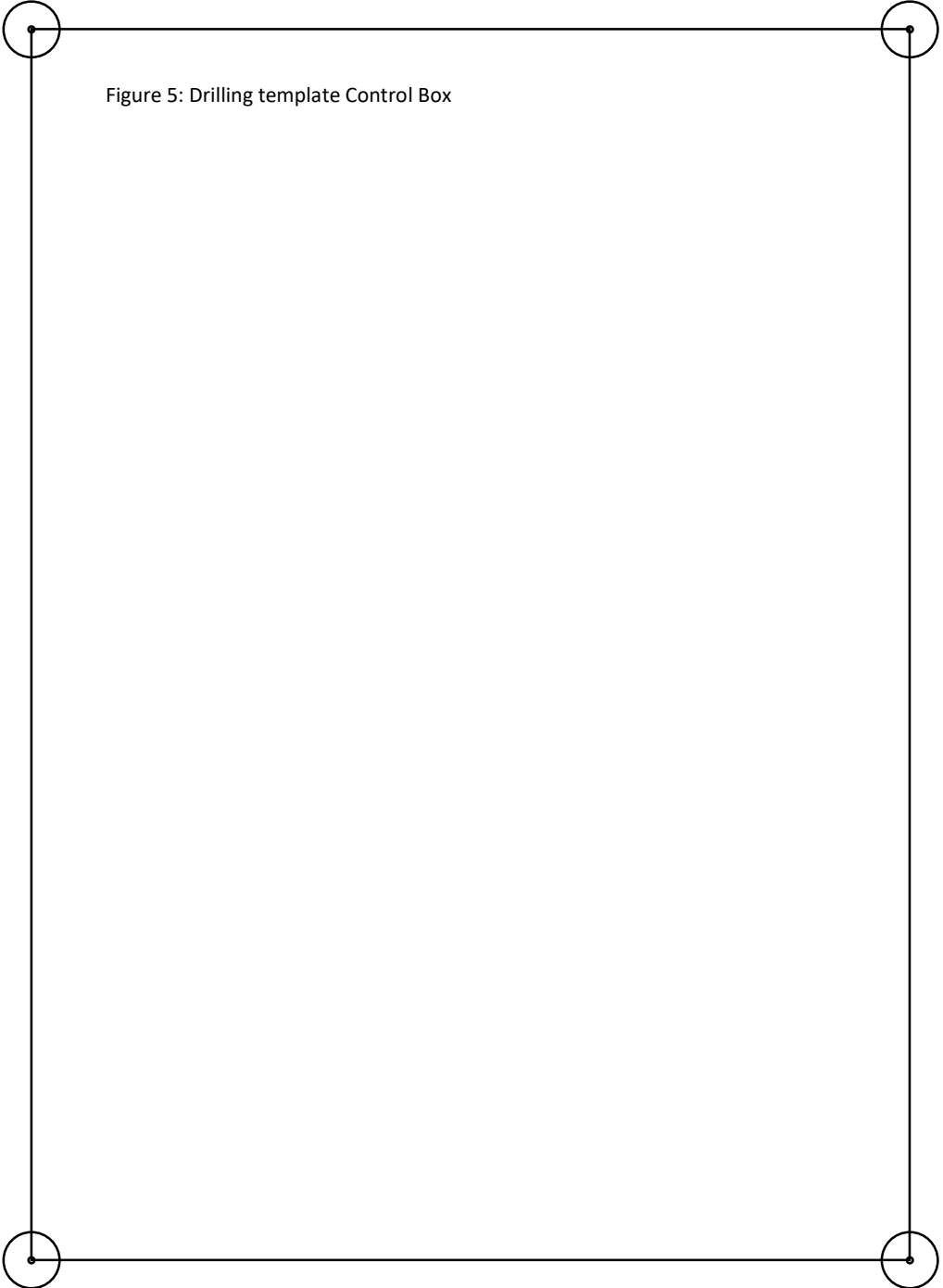
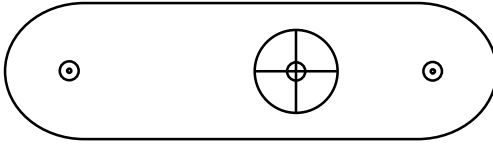

Figure 5: Drilling template Control Box

Figure 6: Drilling template Warning Light



Let`s reduce your Drag...

For all further support, please contact us:

Celerity DRS GmbH

Lise-Meitner-Straße 40
45659 Recklinghausen
Germany

Tel: +49 (0) 2361 306849-14

General email: info@celeritydrs.com